



Instruction Manual

Build-in TV Lift

For cabinets with fixed or hinged lids



- Fixed or Hinged Lid
- Near silent operation <50dB
- 3-year Warranty
- Smartphone app control
- Programmable height
- Auto-reverse on obstruction

**UK
CA**

MBL-700	VESA Compatibility 200x200 200x300 300x200 200x400 400x200 300x300 300x400 400x300 400x400	55" MAX FLAT/CURVED	60kg (132lbs) RATED
MBL-1050	VESA Compatibility 200x200 200x300 300x200 200x400 400x200 300x300 300x400 400x300 600x200 350x350 400x400 600x300 600x400	80" MAX FLAT/CURVED	60kg (132lbs) RATED

Table of Contents

Package Contents	1
Warnings	2
Before Installing	2
Pairing the Remote Control	8
Operating Instructions	8
Mobile App Setup	9
Support and After Sales	11
Troubleshooting	12
Technical Specifications	13

 Read the entire instruction manual before you start installation and assembly. If you have any questions regarding any of the instructions or warnings, please contact your distributor for assistance.

- CAUTION:** Use with products heavier than the rated weights indicated may result in instability causing possible injury.
- Please closely follow the assembly instructions. Improper installation may result in damage or serious personal injury.
 - Safety gear and proper tools must be used. This product should only be installed by professionals.
 - Make sure that the supporting surface will safely support the combined weight of the equipment and all attached hardware components.
 - Use the mounting screws provided and DO NOT OVER TIGHTEN mounting screws.
 - This product contains small items that could be a choking hazard if swallowed. Keep these items away from children.
 - This product is intended for indoor use only. Using this product outdoors could lead to product failure and personal injury.

IMPORTANT: Ensure that you have received all parts according to the component checklist prior to installation. If any parts are missing or faulty, contact your distributor for a replacement.

MAINTENANCE: Check that the product is secure and safe to use at regular intervals (at least every three months).

Package Contents

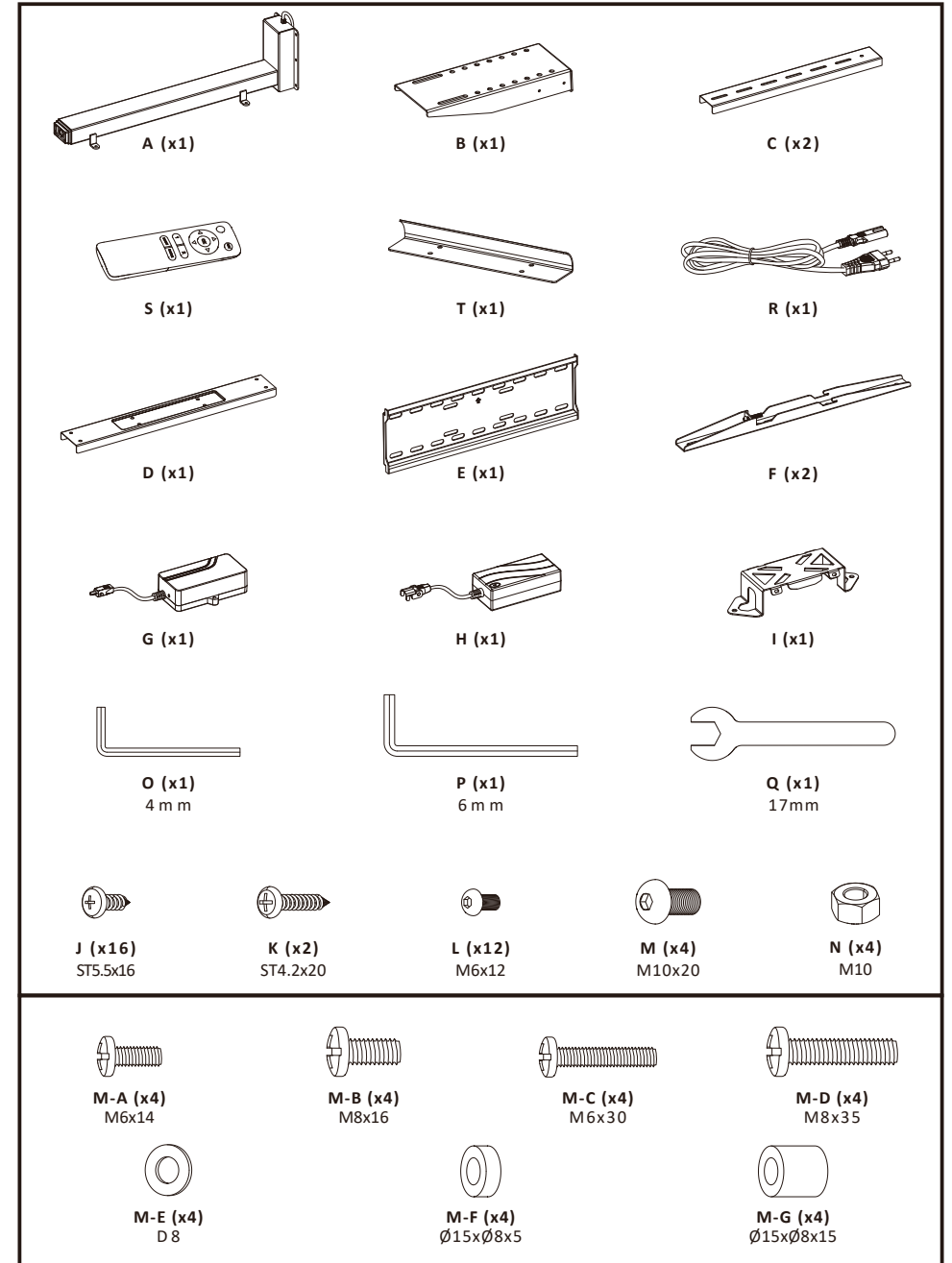

Warnings

The product is powered by electricity. In order to avoid burns, fire and electric shock and make sure the safe and correct use of the system and maintain the longevity of the overall construction and the built-in electronics, please read the instructions carefully.

- This appliance can be used by children aged from 8 years and above if they have been given supervision or instruction concerning use of the appliance in a safe way and understand the hazards involved. Children shall not play with the appliance. Cleaning and user maintenance shall not be made by children without supervision.
- Persons with reduced physical, sensory or mental capabilities or lack of experience and knowledge must not use the appliance, unless they're under supervision, understand the hazards involved or they have been thoroughly instructed in the use of the apparatus by a person who is responsible for the safety of these persons.
- Don't leave the cords or plug unorganised in order to prevent tripping

Electrical Safety Instructions

- The appliance is only to be used with the power supply unit provided with the appliance. Alterations of the given power unit aren't allowed.
- Never operate the system with a damaged power supply cord or plug. If any parts is damaged, please contact your distributor of purchase for a replacement.
- Never operate the system if it's in moist environment or its electrical components has contact with liquids. ·Don't clean the product while the power is still connected.
- Don't disassemble or replace components while the power is still connected.
- Unplug the appliance when the system isn't in use, and place the power plug out of children reach.



Before Installing

It's important to check the performance and functionality of your lift before commencing with the installation into a cabinet. When testing the lift outside the cabinet ensure it is suitably supported and be careful not to place your hands near/on any moving components.

1. Plug the control box to the lift body, and connect the power supply to the control box as shown in installation step 1.
2. Plug the power lead into the power supply then into the your mains wall socket.

You may need to pair your remote control for first time use, refer to the "Pairing the Remote Control" section for instructions on completing this.

Ensure the lift operates as expected along the full stroke height. The motion should be smooth and near silent.

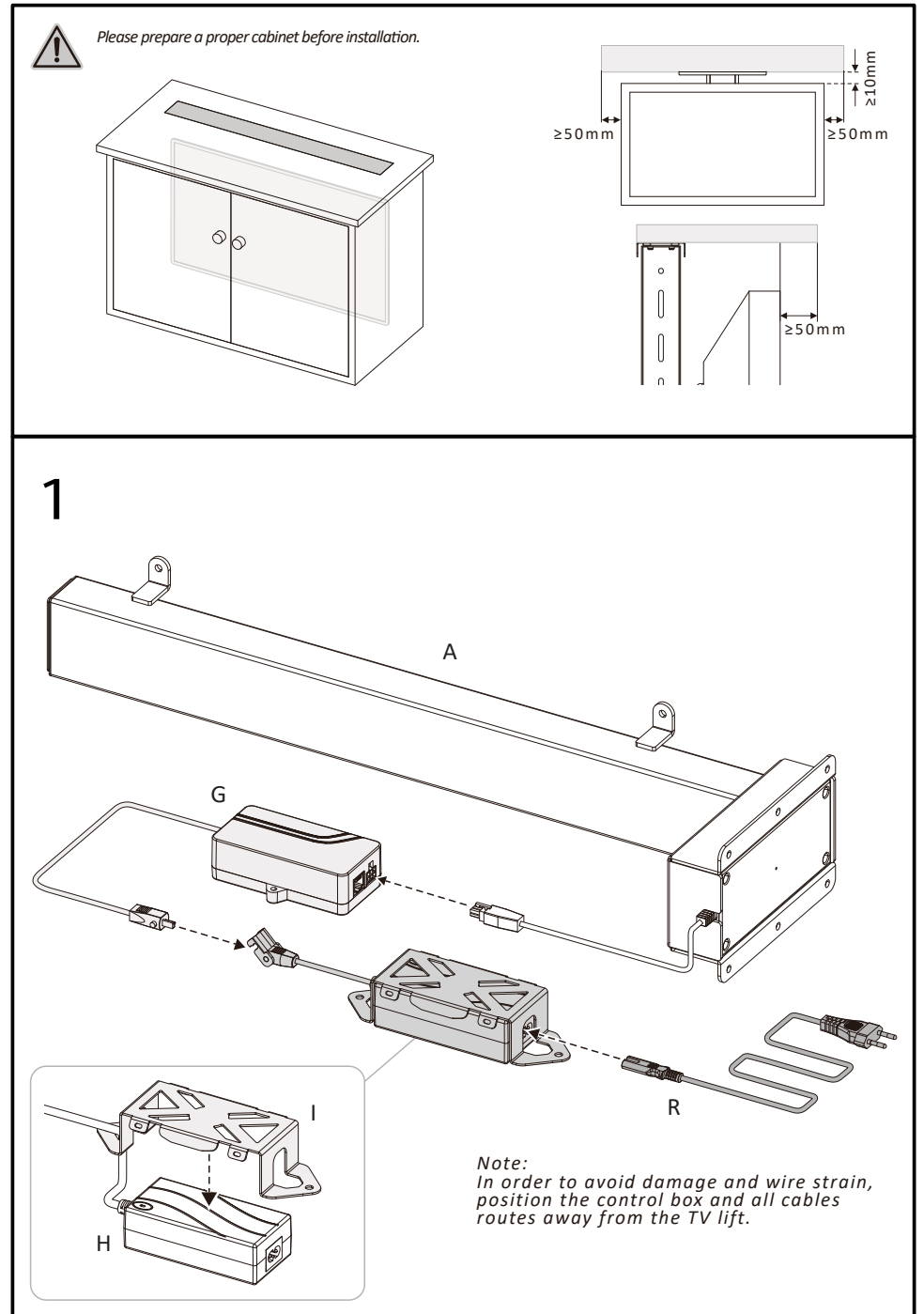

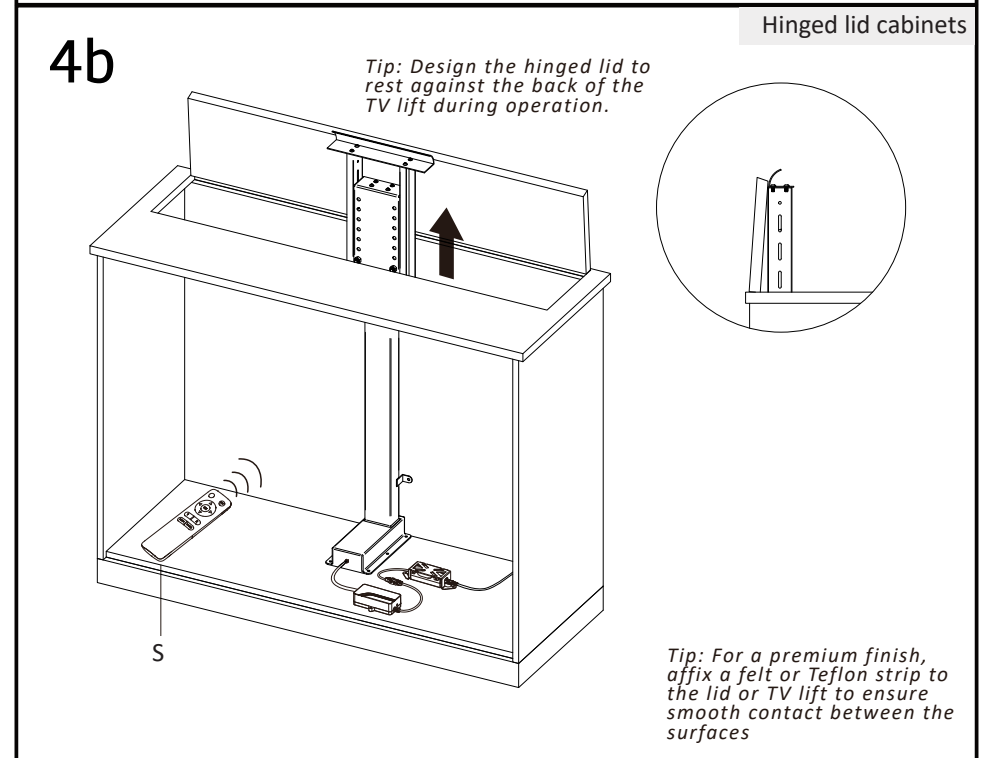
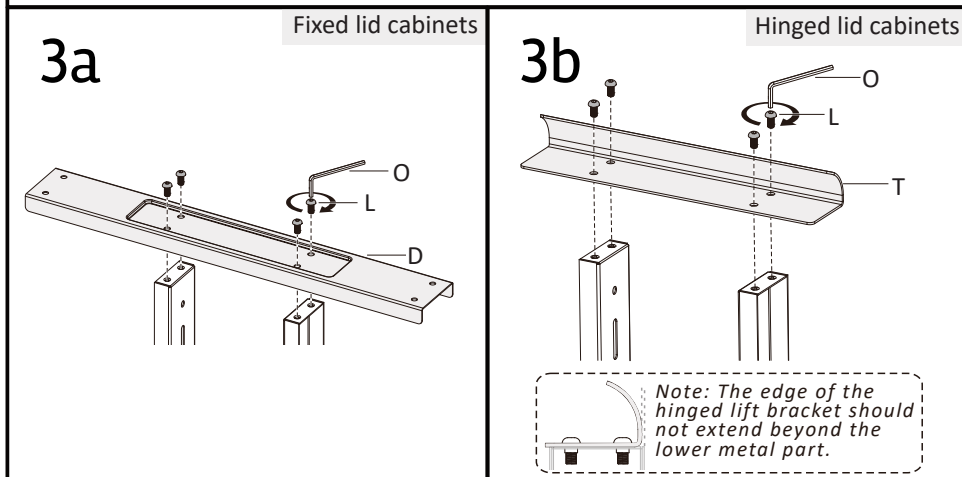
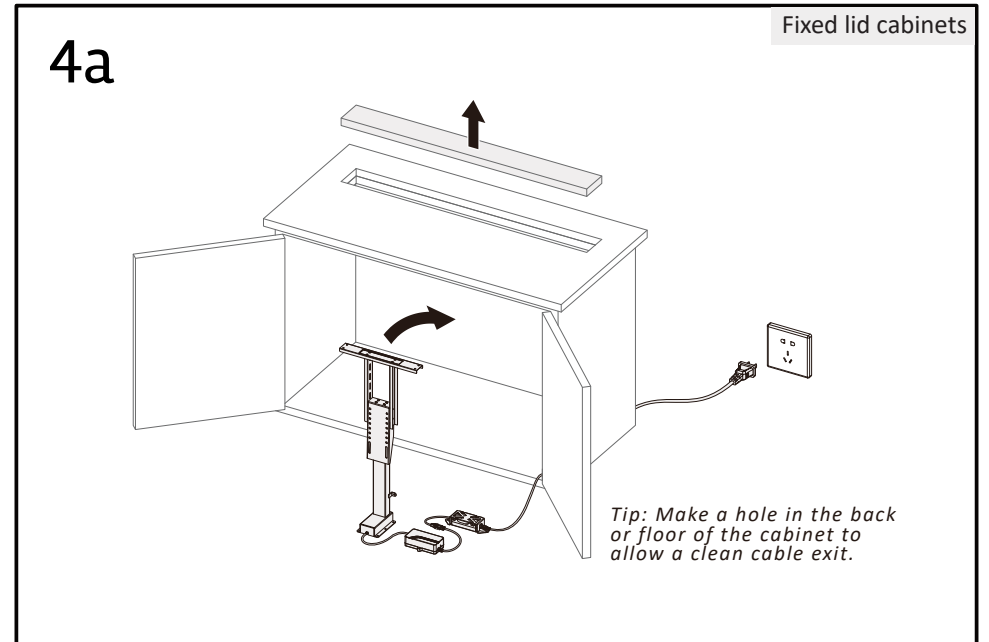
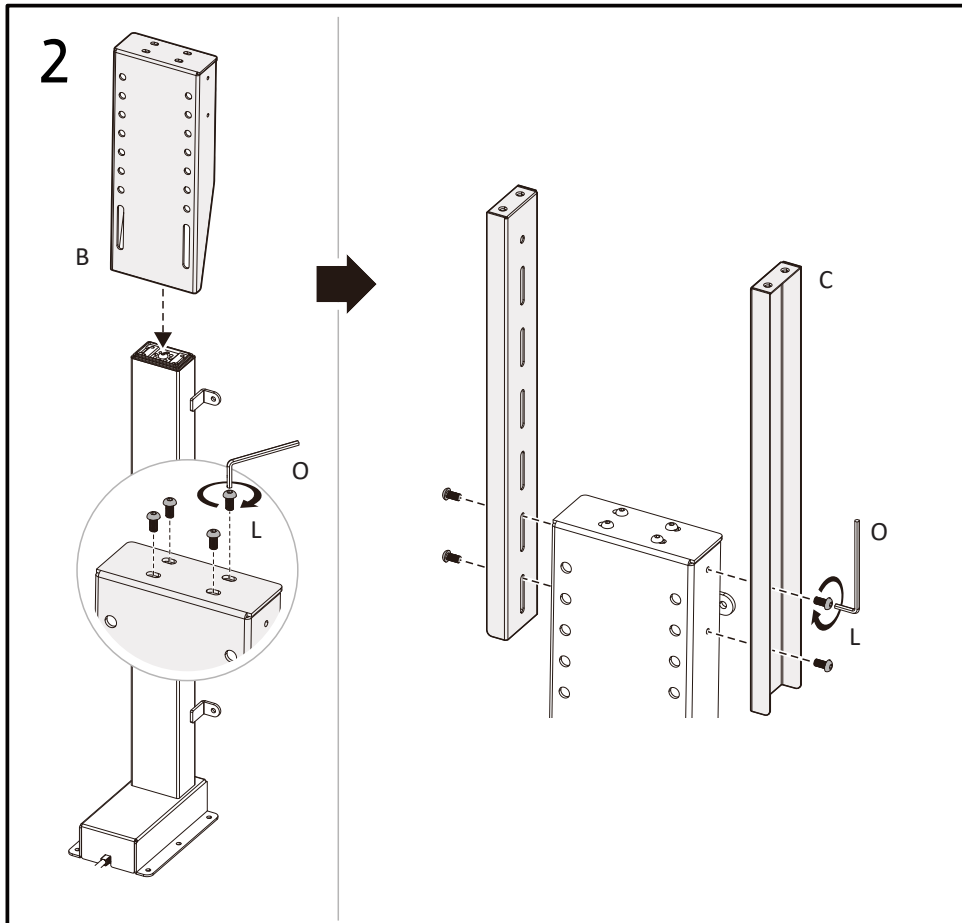

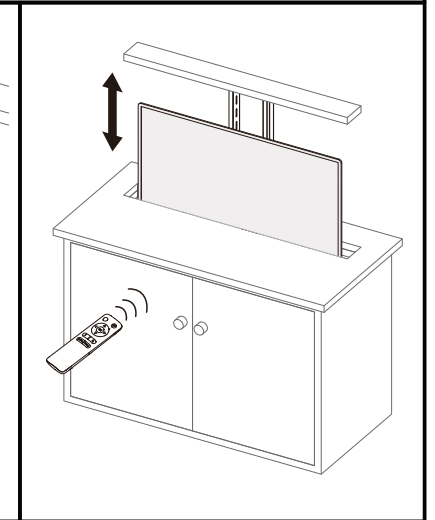
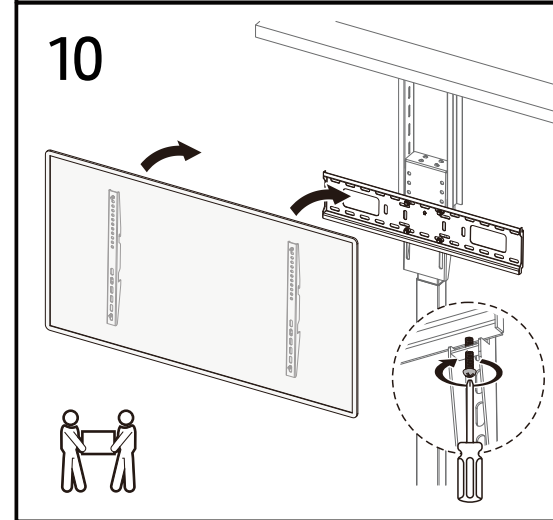
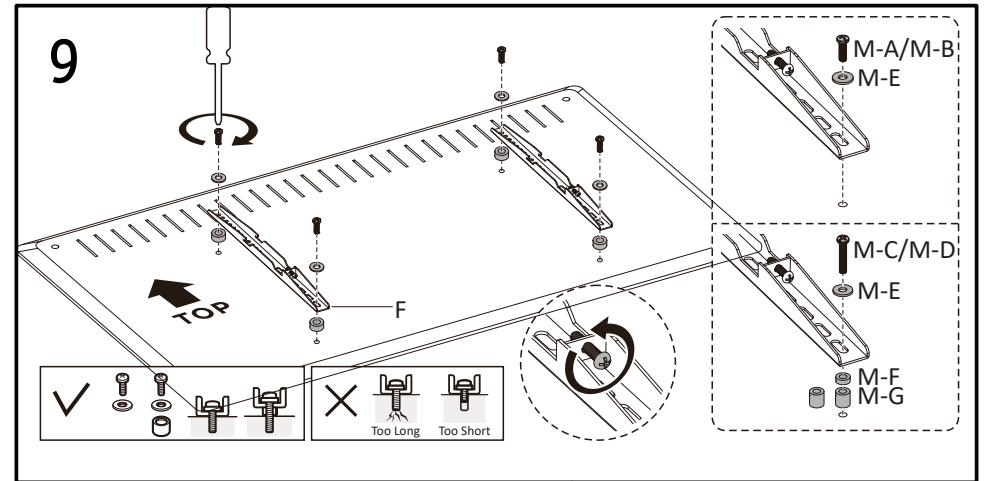
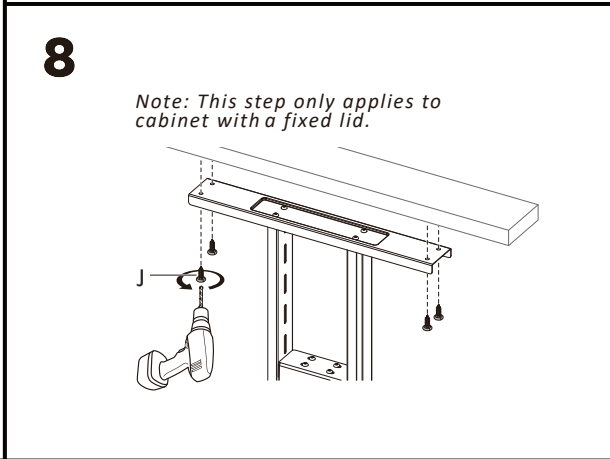
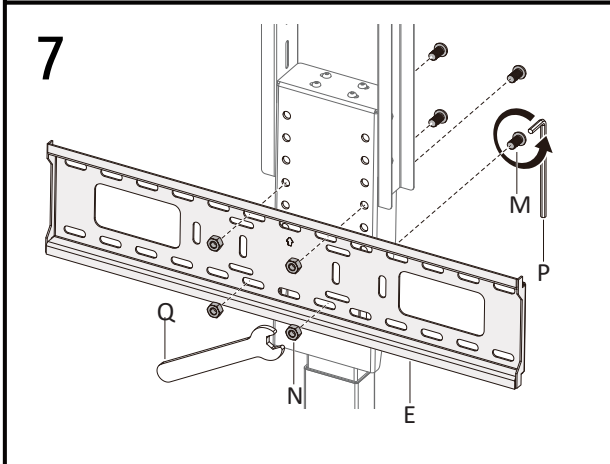
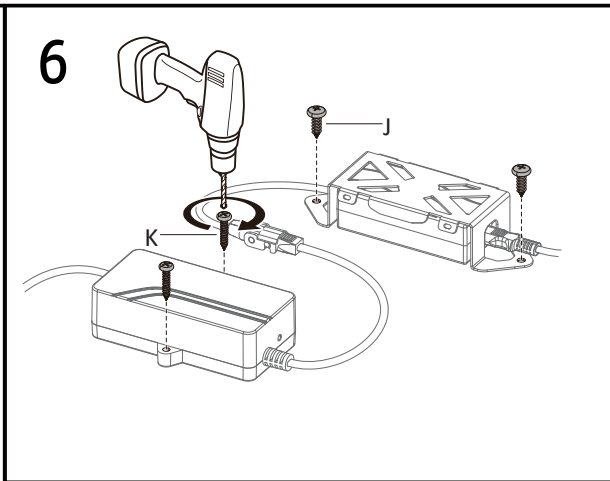
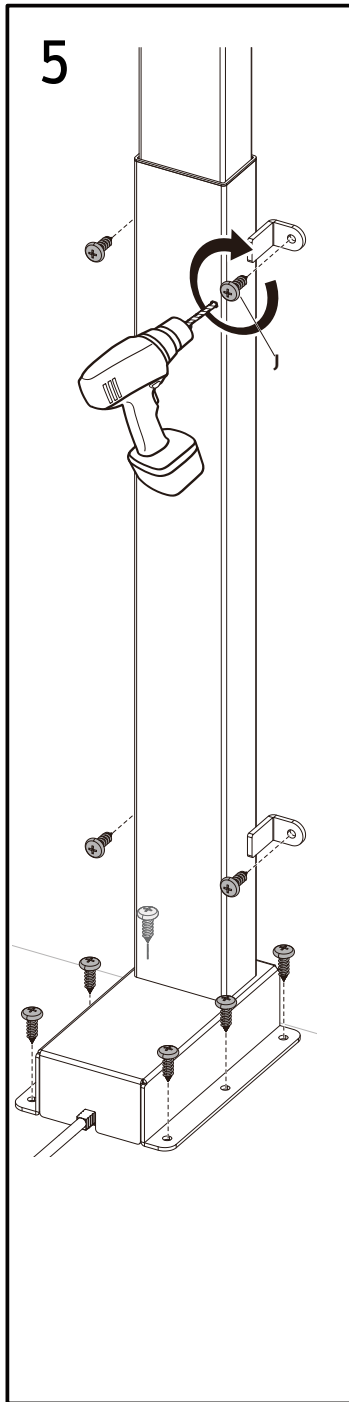

Pairing the Remote Control

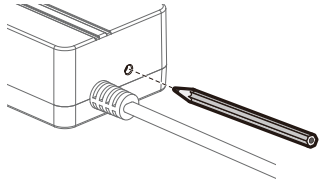

STEP1: With the TV lift powered on, press the small button on the control box with a thin tool as shown. The unit will emit a beep, indicating that the control box is ready for pairing.

STEP2: Press the “SET” button on the remote control. You should hear repeated beeps for approximate 10 seconds indicating that the remote control is being paired. A final beep will indicate success.

Note: To clear any previously paired remote controls press and hold the small button on the control box. You will hear a beep followed by a 2nd beep after 5 seconds. You may now release the button and pair a new remote control.

Operating Instructions

1. Raise/Lower the TV

Press and hold the “△” button to raise and the “▽” button to lower the TV.

2. Memory Settings

Press and hold the “mem1” or “mem2” button for 3 seconds until you hear a beep. This saves the current position into the “1” and “2” buttons.

3. Recall Memory

Press the “1” or “2” button and the TV lift will automatically move to the position saved by the corresponding “mem1” or “mem2” button.

4. Lowest Height Limit

Short press the “mem1” button five times, after each press you will hear a beep and at the 5th press two beeps. This indicates the current height is now saved as the lowest height setting.

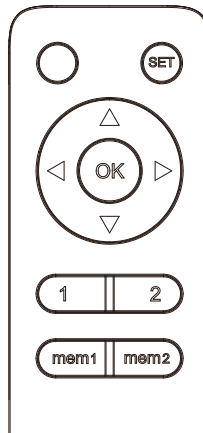

5. Default Setting

To automatically position the TV lift at the lowest settings press the “OK” button. Pressing a 2nd time will stop the TV lift.

6. Reset

Press and hold the “OK” button for 3 seconds until you hear a beep. The TV lift will lower all the way down and then raise a short amount. This will reset the lowest height limit.

7. Mobile app connection

Press the “mem2” button 5 times, after each press you will hear a beep and at the 5th press two beeps. This indicates the TV lift is disconnecting from the Wi-Fi. A further one beep indicates the TV lift has been disconnected and is ready to be discovered by the Tuya app again.

See the “Mobile App Setup” page for instructions on setting up control via the Tuya mobile app.

Mobile App Setup

The TV lift is controllable through a mobile app named Tuya Smart. Once setup, you and other household members can operate the lift through the mobile app. It's also possible to configure the Tuya app to integrate with voice assistants like Amazon Alexa and Google Assistant.

- This guide is for illustration purposes only, the screenshots, steps and procedures may be different in the latest version of the app.
- The app requires the setup of a free account with Tuya but you can test the functionality as a guest.
- The TV lift is capable of connecting to 2.4GHz Wi-Fi networks.
- Sharing the TV lift with other household members and use of voice assistants requires internet access.

Obtaining the App

The app is available on the Google Play store and Apple's App store, scan the correct QR code below to get started.

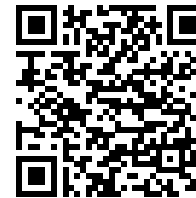

The following steps and screenshots are for guidance only as the app may have changed since this manual was printing.



1. Create an account or sign in to an existing account. Follow the instructions for verification (email or SMS) on the screen.

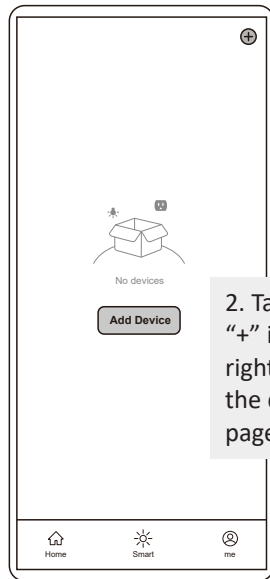

2. Tap "Add Device" / "+" icon in the upper right corner to enter the device selection page.

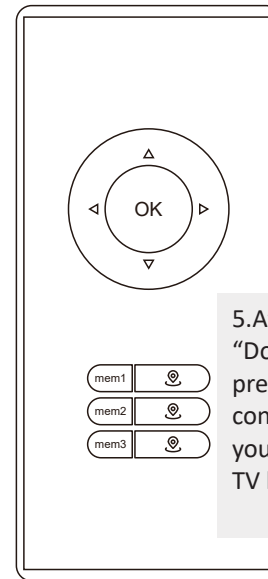

5. After tapping "Done" you'll be presented with the control screen where you can operate your TV lift.

The Tuya app has built in FAQ and help pages for further assistance configuring your app and other devices.

Tuya App Support
www.tuya.com
support@tuya.com

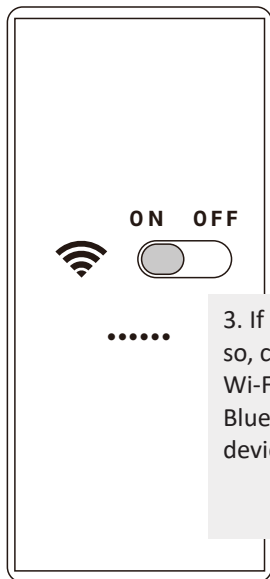

3. If prompted to do so, connect to the Wi-Fi and allow Bluetooth nearby device scanning.

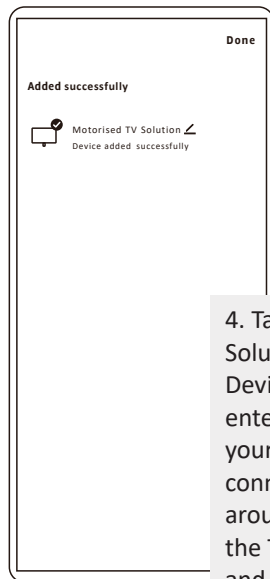

4. Tap "Motorised TV Solution" in the Add Device screen and enter the details of your Wi-Fi connection. After around 60 seconds the TV lift will beep and will be added to the app.

Support and After Sales

If you experience issues operating your lift or need advice, you should get in touch with your distributor.

Thank you for choosing our TV Lift product. We hope you are satisfied with your purchase and enjoy its features and benefits. If you have any questions or concerns about your purchase, please refer to this user manual or contact your distributor.

Your lift is covered by a 3-year warranty period from the date of purchase, during which we will repair or replace your product free of charge if it is defective or malfunctioning.

To claim your warranty, please keep your receipt and contact your distributor. We value your feedback and appreciate your custom.

Troubleshooting

This troubleshooting guide will assist you in identifying and solving common problems and answering questions you may have about the product. Contact your distributor should the answer to your question or problem not be found in this troubleshooting guide and/or for any after service parts and sales support.

1. Possible reasons the TV Lift doesn't respond to the remote control.
 - a. TV Lift
 - If the TV lift beeps 3 times after pressing any button, the TV lift is in an error state and requires a reset. Please follow step 6 of the operating instructions.
 - If the TV lift beeps 4 times after pressing any button the lift may have shut down to prevent overheating. This can happen when the lift has been operated a lot within a short period of time. The control box should resume normal operation after a short while.
 - Check the all the connections and switches between the wall socket and the TV lift.
 - If the TV lift beeps once after pressing a button this indicates incorrect operation. Please refer to the Operating Instructions for proper use of the TV lift.
 - b. Remote Control
 - The distance between the remote control and the TV lift may be too large. An acceptable range should be less than 10m (30 ft).
 - The batteries in the remote control may be low. Replace the batteries.
 - The remote control may be broken. Check to see if the indicator LED found at the top left of the remote lights when a button is pressed. If not, contact your distributor for a replacement.

2. TV Lift stops moving during operation and emits a long beep.
 - Check to see if an obstacle is present that impedes the free movement of the lift. Remove if present and retry.
 - The weight of the TV may exceed the maximum weight limitation.
 - The motor wire may be broken, reset the TV lift. If the problem still exists contact your distributor for a replacement.

3. TV Lift is making an abnormal noise or sound
 - Check all connections and reset the TV lift. If noise continues contact your distributor for advice or purchase a replacement.

Technical Specifications

	MBL-700	MBL-1050
Material	Aluminium, Steel, Plastic	
Surface Finish	Powder Coating	
Colour	Matte Black	
Dimensions (Fixed lid bracket)	205x500x640-1650mm	205x660x810-2170mm
Lift Stroke (Lifting height)	700mm	1050mm
Compatible Screen Sizes	32" - 55"	37" - 80"
VESA Compatibility	200x200, 200x300, 300x200, 200x400, 400x200, 300x300, 300x400, 400x300, 400x400	200x200, 200x300, 300x200, 200x400, 400x200, 300x300, 300x400, 400x300, 600x200, 350x350, 400x400, 600x300, 600x400
Weight Capacity	60kg	
Installation Type	Inside Cabinet	
Profile (Back of cabinet to rear of TV)	120mm	
Power Supply	Input: AC 100-240V, 50/60Hz; Output DC 29V, 1.8A	
Power Cord Length:	1.5m	
Controller Type	Radio Frequency (RF) Remote	
Wi-Fi Standard	2.4GHz 802.11 B/G/N	
Certification	CE, FCC, RoHS, UKCA	



Disposal:

The product with this mark indicates that this product shouldn't be disposed with other household wastes throughout the EU. To prevent possible harm to the environment or human health from uncontrolled waste disposal, recycle it responsibly to promote the sustainable reuse of material resources. To return your used device, please use the local recycle service or contact your point of purchase to withdraw the product.

Notes:
